

4

3

2

1

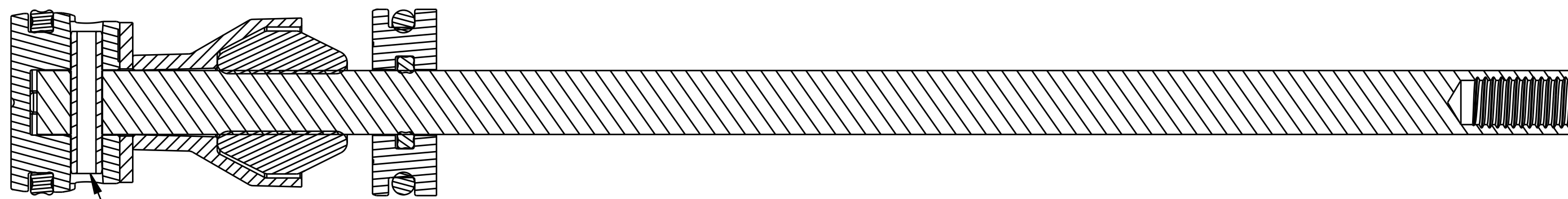

! IMPORTANT:  
ORIENT GAP IN PIN TOWARDS  
TOPOUT SPACER  $\pm 15^\circ$

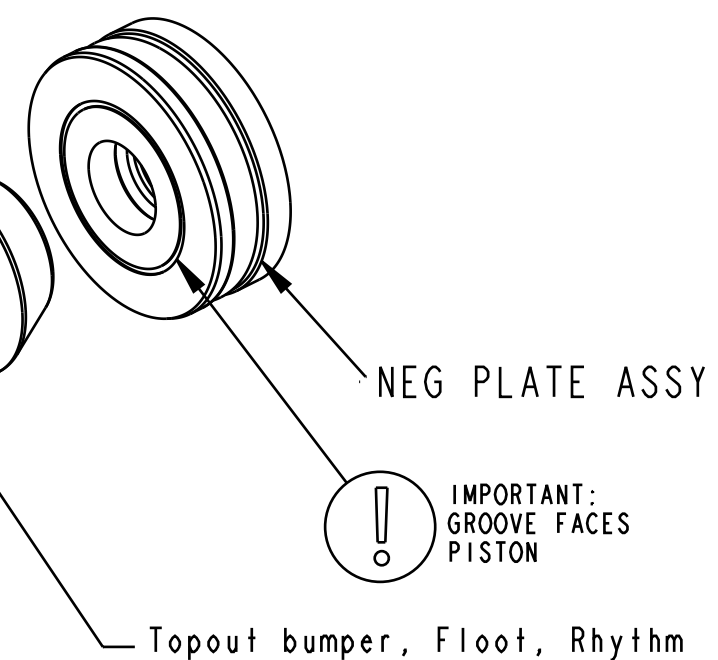

! IMPORTANT:  
GROOVE FACES  
PISTON

NEG PLATE ASSY

Topout bumper, Float, Rhythm

Topout spacer, Float, Rhythm

GREASE:  
THIN LAYER  
OF SLICK HONEY

SHAFT

! IMPORTANT:  
VERIFY SEAL IS NOT  
TWISTED AFTER INSTALL

Fastener, Standard: Flat Washer [10mm ID X 26 OD]

Pin: Spring [Ø 0.188 X 0.875 TLG] Spring Steel, Zinc

PISTON

SEAL: O-RING

**FOX** FOX Factory, Inc. Ph 831-768-1100  
 130 Hangar Way, Watsonville, CA 95076 USA Fax 831-768-9312  
 TITLE 2025 Z2 and Z2 E-Opt  
 Direct Mount Air Shaft Assys

SIZE DWG. NO. C  
 PLOT SCALE 1, 3: 1 SHEET 1 OF 1

- PROPRIETARY -  
 THIS DOCUMENT CONTAINS CONFIDENTIAL, PROPRIETARY INFORMATION  
 THAT IS FOX PROPERTY. DO NOT DISCLOSE TO OR DUPLICATE  
 FOR OTHERS EXCEPT AS AUTHORIZED BY FOX.

4

3

2

ProE ASSEM